

# 856H

## WHEEL LOADER

EU Stage V



## SPECIFICATIONS

### Operating weight 18,600 kg (41,006 lb)

Operating weight includes the machine weight with standard work device, no additional equipment or accessories, full fuel tank, all fluids at required level and an operator 75 kg (165 lbs).

Bucket capacity 2.6 - 5.6 m<sup>3</sup> (3.4 - 7.3 yd<sup>3</sup>)

### ENGINE

#### Description

Cummins EU Stage V-approved, 6.7 liter (1.8 gal), 6-cylinder straight turbocharged diesel engine with common rail fuel injection system and cooled Exhaust Gas Recirculation (EGR). Cummins Variable Geometry Turbocharger (VGT) improves engine response at both low and high speed RPM.

Cummins CM2350 (improved microprocessor and memory) ECM lever latch connections. Integrated DEF controller.

Auto idle – saves fuel, idle time is 10 mins, idle speed at 700 rpm.

Air cleaning: Cummins direct flow air filter.

Cooling system: Air-to-air intercooler, hydraulic motor drive and temperature controlled fan.

Emission rating	EU Stage V
Make	Cummins
Model	QSB 6.7
Engine Output - Max Gross (SAE J1995 / ISO 14396)	245 hp (183 kW) @ 2,000 rpm
Engine Output - Rated Net (SAE J1349 / ISO 9249)	225 hp (168 kW) @ 2,000 rpm
Peak torque	1,186 N·m (874 lbf-ft)
Displacement	6.7 L (1.8 gal)
Number of cylinders	6
Aspiration	Turbocharged & Air-to-air intercooled

### AXLES

Model	AP3000 (Wet type)
Differential front type	Limited slip
Differential rear type	Limited slip
Axle oscillation	±12°

### TRANSMISSION

#### Option 1

Torque converter: single-stage, three elements.

Transmission: ZF 5WG 210 countershaft transmission, integrated pilot single joystick with FNR, KD and horn. Electro proportional valve, continuous power in gears shift and less compact.

Gear shifting system: ZF Ergopower Power Shift with auto modes (1~4/2~4) all start in gear 2, faster and better for long distance material transport.

Transmission type	Countershaft, power shift
Torque converter	Single stage, three elements
Max. travel speed, fwd	39 km/h (24.2 mph)
Max. travel speed, rev	27.8 km/h (17.3 mph)
Number of speed, fwd	5
Number of speed, rev	3

#### Option 2

Torque converter: single-stage, three elements.

Transmission: ZF 4BP 210 countershaft transmission, integrated pilot single joystick with FNR, KD and horn. Electro proportional valve, continuous power in gears shift and less compact.

Gear shifting system: ZF Automatic Power Shift with auto modes (1~4/2~4) all start in gear 2, faster and better for long distance material transport.

Transmission type	Countershaft, power shift
Torque converter	Single stage, three elements
Max. travel speed, fwd	38.6 km/h (24 mph)
Max. travel speed, rev	24.9 km/h (15.5 mph)
Number of speed, fwd	4
Number of speed, rev	3

### HYDRAULIC SYSTEM

#### Description

System supply: Two load-sensing axial piston pumps with variable displacement. The steering function always has priority. Valves: Double-acting 3-spool valve. The main valve is controlled by a 3-spool pilot valve.

Lift function: The valve has four positions: lift, hold, lower, and float. Inductive/magnetic automatic boom kick-out can be switched on and off and is adjustable to two positions: bucket at ground Level and maximum reach full lifting height.

Tilt function: The valve has three functions: rollback, hold and dump.

Cylinders: Double-acting cylinders for all functions.

Filter: Full-flow filtration through 12 micron (absolute) filter cartridge.

Main pump type	Piston
Main relief pressure	22 MPa (3,191 psi)
Raise	5.3 s
Dump time	1 s
Float down time	3 s
Fastest total cycle time	9.3 s
Controls	Joystick or 3 levers

### BRAKES

#### Description

Two independent brake circuits, disks out of rim, accurate control with the advanced main valve & piston pump.

Service brake type	Wet discs brake, two independent circuits
Service brake actuation	Hydraulic
Parking brake type	Manual electronic control
Parking brake actuation	Hydraulic

### SERVICE REFILL CAPACITY

Fuel Tank	270 L (71.3 gal)
Engine Oil	18 L (4.8 gal)
Cooling System	44 L (11.6 gal)
Hydraulic System	252 L (66.6 gal)
Transmission and Torque Converter	35 L (9.3 gal)
Axles, Each	44 L (11.6 gal)
DEF Tank	49.2 L (13.0 gal)

## STEERING

### Description

Steering system: Load-sensing hydraulic articulated steering.

System supply: The steering system has priority feed from a load-sensing axial piston pump with variable displacement, Dual-pump confluence & Steering priority.

Steering cylinders: Two double-acting cylinders.

Steering configuration	Articulated
Steering relief pressure	18 MPa (2,611 psi)
Steering cylinders	2
Cylinder bore	90 mm (4")
Rod diameter	50 mm (2")
Stroke	465 mm (1' 6")
Maximum flow	140 L/min (37 gal/min)
Maximum articulation	±38°
Smallest turn (over tire)	6,205 mm (20' 4")

## SOUND & ENVIRONMENT

Sound level in cab according to ISO 6396-2008/EN ISO 3744-1995	69 dB(A)-- Travel mode
Sound level in cab according to ISO 6396-2008/EN ISO 3744-1995	70 dB(A)-- Stationary work cycle mode
External sound level according to ISO 6395-2008	105 dB(A)-- Travel mode
External sound level according to ISO 6395-2008	106 dB(A)-- Stationary work cycle mode
Ventilation	9.2 m <sup>3</sup> (12 yd <sup>3</sup> )
Heating capacity	5.8 kW (7.8 hp)
Air conditioning	6 kW (8 hp)

## ELECTRICAL SYSTEM

### Description

Central warning system is a centralized electrical system with central warning light and buzzer for following functions: Serious engine fault, Low steering system pressure, Interruption in communication (computer failure), Low engine oil pressure, High engine oil temperature, High charge-air temperature, Low coolant level, High coolant temperature, Low transmission oil pressure, High transmission oil temperature, Low brake pressure, Engaged parking brake, Brake charging failure, High hydraulic oil temperature.

Voltage	24 V
Batteries	2 x 12 V
Battery capacity	2 x 120 Ah
Cold cranking capacity, approx	850 A
Reserve capacity	230 min
Alternator rating	1,960 W / 70 A
Starter motor output	4.8 kW (6.4 hp)

## CAB

### Description

Instrumentation: All important information is centrally located in the central instrument panel and operator's field of vision. Large curved front glass, rear view camera and mirrors ensure great visibility.

Adjustable steering column, air suspension seat, armrest box and Denso A/C with all-around air outlets.

Pressurized cab with lower interior noise. The cab is tested and approved according to ROPS (ISO 3471), FOPS (ISO 3449).

## LOADER ARM PERFORMANCE

### Description

Tipping Load data is calculated with standard bucket at 3.1 m<sup>3</sup> (4.1 yd<sup>3</sup>) and operating weight at 18,600 kg (41,006 lb).

Tipping load - straight according to ISO 14397-1:2007	13,400 kg (29,542 lb)
Tipping load - full turn according to ISO 14397-1:2007	11,700 kg (25,794 lb)
Bucket breakout force	187 kN (42,039 lbf)
A Maximum hinge pin height	4,028 mm (13' 3")
B Dump clearance at full height discharge	3,084 mm (10' 1")
C Dump reach at full height discharge	1,125 mm (3' 8")
D Maximum digging depth, bucket level	30 mm (1")
S <sub>1</sub> Bucket rollback at ground level	42°
S <sub>2</sub> Bucket rollback at carry	47°
S <sub>3</sub> Bucket rollback at maximum height	60°
S <sub>4</sub> Maximum dump angle at full height	45°

## DIMENSIONS

E Ground clearance	431 mm (1' 5")
G Wheelbase	3,320 mm (10' 11")
H Cab height	3,450 mm (11' 4")
J Wheel tread	2,150 mm (7' 1")
K Width over tires	2,750 mm (9')
L Length with bucket down	8,318 mm (27' 3")
M Turn angle, either side	38°
P Rear angle of departure	27°
R <sub>1</sub> Turning radius, bucket carry	6,954 mm (22' 10")
R <sub>2</sub> Turning radius, outside of tire	6,205 mm (20' 4")

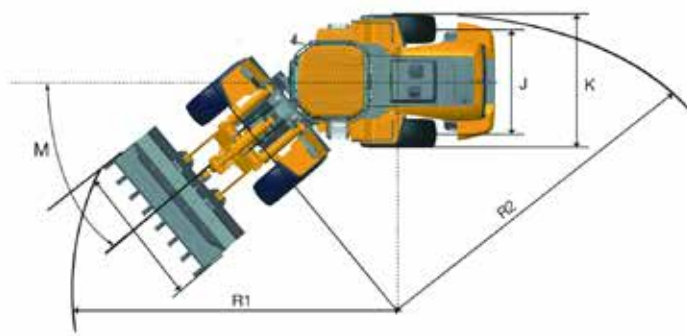
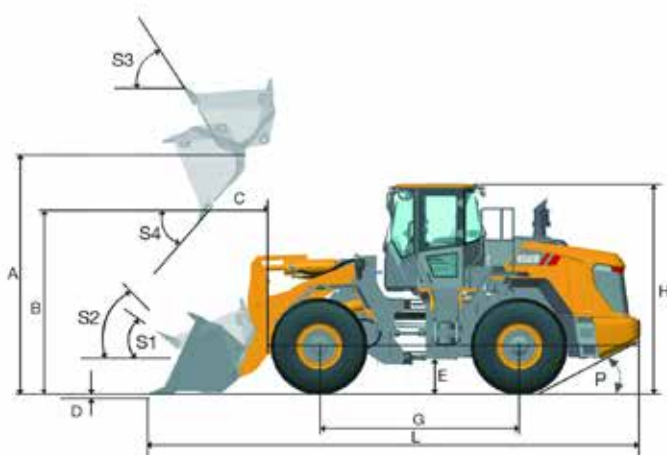

## TIRES

Choosing the right tyres for your machine will become a key competitive advantage to achieve outstanding performance. Through close engineering and development cooperation with renowned and carefully selected suppliers, LiuGong can offer full range of tyres specially tailored for wheel loader.

Code	Application	Patterns	Size	PR / *	Tube Type	Width	Overall Diameter	Tread Depth	Load Capacity, 50 km/h / 10 km/h (31.1 mph / 6.2 mph)
L2	<ul style="list-style-type: none"> <li>where good traction is needed, e.g. at grading work</li> <li>in soft and muddy operation where sharp stones don't occur</li> <li>in all load/carry operations</li> </ul>		23.5 - 25	12	TL	595 mm (1' 11")	1,615 mm (5' 4")	29.5 mm (1")	3,650 / 6,150 kg (8,046.9 / 13,558.4 lb)
			23.5 - 25	16	TL	595 mm (1' 11")	1,615 mm (5' 4")	29.5 mm (1")	6,150 / 9,500 kg (13,558.4 / 20,943.9 lb)
L3	<ul style="list-style-type: none"> <li>in sand operation</li> <li>in all kind of load/carry operation</li> <li>the L3-tread is not as open as L2 and has consequently less self-cleansing compared with an L2 tyre</li> </ul>		23.5 - 25	16	TL	595 mm (1' 11")	1,615 mm (5' 4")	35 mm (1")	6,150 / 9,500 kg (13,558.4 / 20,943.9 lb)
			23.5 - 25	20	TL	595 mm (1' 11")	1,615 mm (5' 4")	35 mm (1")	7,300 / 10,900 kg (16,093.7 / 24,030.4 lb)
			23.5 - 25	24	TL	595 mm (1' 11")	1,615 mm (5' 4")	35 mm (1")	8,000 / 13,200 kg (17,637 / 29,101 lb)
			23.5 R 25	*	TL	600 mm (2")	1,617 mm (5' 4")	36 mm (1")	7,100 / 12,150 kg (15,652.8 / 26,786.1 lb)
L5	<ul style="list-style-type: none"> <li>in very aggressive material where good protection against cut damages is demanded, e.g. in quarries or mines</li> </ul>		23.5 R 25	*	TL	600 mm (2")	1,704 mm (5' 7")	78 mm (3")	12,150 kg, 10 km/h (26,786.1 lb, 6.2 mph)
			23.5 R 25	**	TL	600 mm (2")	1,704 mm (5' 7")	78 mm (3")	14,500 kg, 10 km/h (31,967.03 lb, 6.2 mph)

Note: The radial tire-load bearing capacity is indicated by the number of stars (\*). More stars, greater radial tire-load bearing capacity. For the specific radial tire sizes listed in the table above, 2 stars (\*\*) represents the maximum radial tire-load bearing capacity.

## ATTACHMENTS

LiuGong attachments with pin-on or quick-coupler ensure high quality. The integrated design of the system creates a perfect match to achieve superior productivity.

Type	Capacity	Width	Height	Digging Depth	Dump Clearance	Dump Reach	Description	Attachment Drawing
General Purpose	2.6 m <sup>3</sup> (3.4 yd <sup>3</sup> )	2,900 mm (9' 6")	1,347 mm (4' 5")	35 mm (1")	3,075 mm (10' 1")	1,008 mm (3' 4")	Anti-Wear Blade with Welded Teeth.	
	3 m <sup>3</sup> (3.9 yd <sup>3</sup> )	2,900 mm (9' 6")	1,303 mm (4' 3")	35 mm (1")	2,983 mm (9' 9")	1,100 mm (3' 7")	Anti-Wear Blade with Bolt-on Cutting Edge and Bolt-on Teeth.	
	3.3 m <sup>3</sup> (4.3 yd <sup>3</sup> )	2,900 mm (9' 6")	1,314 mm (4' 4")	35 mm (1")	2,955 mm (9' 8")	1,129 mm (3' 9")	Bolt-on Cutting Edge; Bolt-on Teeth; Bolt-on Cutting Edge and Bolt-on Teeth.	
	3.5 m <sup>3</sup> (4.6 yd <sup>3</sup> )	2,900 mm (9' 6")	1,382 mm (4' 6")	35 mm (1")	2,877 mm (9' 5")	1,206 mm (3' 12")	Bolt-on Cutting Edge; Bolt-on Teeth.	
Light Material	4.2 m <sup>3</sup> (5.5 yd <sup>3</sup> )	3,168 mm (10' 5")	1,429 mm (4' 8")	67 mm (2")	2,802 mm (9' 2")	1,236 mm (4' 1")	Bolt-on Cutting Edge.	
	4.7 m <sup>3</sup> (6.1 yd <sup>3</sup> )	3,168 mm (10' 5")	1,445 mm (4' 9")	67 mm (2")	2,697 mm (8' 10")	1,338 mm (4' 5")	Bolt-on Cutting Edge.	
	5.6 m <sup>3</sup> (7.3 yd <sup>3</sup> )	3,150 mm (10' 4")	1,561 mm (5' 1")	67 mm (2")	2,733 mm (9' 0")	1,350 mm (4' 5")	Bolt-on Cutting Edge; Bolt-on Cutting Edge and Welded Teeth.	
Rock	2.7 m <sup>3</sup> (3.5 yd <sup>3</sup> )	2,866 mm (9' 5")	1,390 mm (4' 7")	77 mm (3")	2,919 mm (9' 7")	1,096 mm (3' 7")	V-Shape Anti-Wear Blade.	
Grapple	Φ1,000 mm (3' 3")	2,640 mm (8' 8")	1,732 mm (5' 8")	62 mm (2")	2,610 mm (8' 7")	1,678 mm (5' 6")	Aligned Teeth.	
	Φ350 mm (1' 2")	2,600 mm (8' 6")	1,520 mm (5')	62 mm (2")	2,862 mm (9' 5")	1,485 mm (4' 10")	Crossed Teeth.	

# STANDARD EQUIPMENT

## ENGINE

- Cummins QSB6.7, EU Stage V, engine output-rated net power 225 hp (168 kW), air-to-air intercooled, 6 cylinders, 4 stroke
- High Pressure Common Rail
- Exhaust emission control
- DC air filter, fuel filter
- Intelligent Power Control (IPC)
- Hydraulic driven reversible fan
- Grid heater

## TRANSMISSION

- ZF Ergopower 5WG210 automatic power shift transmission with electrical lock-up
- Kick-down function, FNR, F5/R3
- Transmission oil level sight gauge
- Secondary oil filter, oil stick
- Remote pressure taps for diagnostics
- Auto shifting mode by speed
- Interlock between parking brake and gear shifting

## AXLE

- ZF wet axle with limited slip differentials
- Wet discs service brake system
- Parking brake service as secondary

## HYDRAULIC SYSTEM

- Two piston pumps with variable displacement. Hydraulic load-sensing according to demand
- Third valve and multipurpose lines
- Single joystick control
- Boom kick-out, automatic
- Bucket positioner, automatic
- Plug at the port of bucket and boom cylinder for pressure check
- Emergency boom lower via pilot accumulator

## STEERING SYSTEM

- Load sensing system with flow amplification and steering priority
- Emergency steering system

## TIRE & RIM

- 23.5R25\*/L3 Radial tire
- Full fender

## CHASSIS FRAME

- Spacious central articulation arrangement with conic bearing
- Articulation locking bar
- Tow hitch
- Rubber cushion articulation stops

## LINKAGE & ATTACHMENTS

- Z-bar linkage

## ELECTRIC SYSTEM

- Two front lights with high/low beam
- Four front headlights on top of cab
- Four rear headlight on top of cab
- Turn signals with flasher
- Batteries, free of maintenance
- Cigarette lighter, 24 V power outlet
- Electric horn
- Front and rear windshield wiper
- Electronic device compartment
- Back-up alarm
- Radio/player with USB port
- Reversing warning light, automatic
- Rotating beacon
- License-plate bracket and light

## GAUGE GROUP

- Engine coolant temperature
- Transmission oil temperature
- Fuel level
- Hour meter
- Voltage
- Brake oil pressure

## INDICATOR GROUP

- Air inlet heater
- Battery charging
- Parking brake applied
- Machine emergent stop
- Power cut-off
- Engine servicing
- Turning lights
- Engine starter running
- Beam of front light

## CAB

- Certified FOPS (ISO 3449) and ROPS (ISO 3471) cab
- Seat - mechanical suspension with 3 inch seat belt
- 4-way adjustable steering column
- Large curved front glass
- Rubber cab mounts
- Cab fresh air filter
- One interior & dual exterior rear-view mirrors
- Rear-view camera display
- Air conditioner
- Lunch-box/cooler holder
- One beverage holder
- Cigarette lighter
- Cab rear window defroster
- Sun visors
- Fire extinguisher

## OTHERS

- Manual central lubrication
- Wedge block

# OPTIONAL EQUIPMENT

## ENGINE

- Cold start aid

## TRANSMISSION

- ZF 4BP 210 automatic transmission

## AXLE

- ZF wet axle without limited slip differentials

## HYDRAULIC SYSTEM

- Electric Proportional Controller
- Ride control

## TIRE & RIM

- See tires options
- Normal fender
- Tire protective chain

## CAB

- Heated air suspension seat
- Heated external rear view mirrors
- Cab dust removal device
- Front windshield screen (must be mounted at factory)

## LINKAGE & ATTACHMENTS

- Quick coupler
- Additional counterweight
- High/extra-high linkage
- Bolt-on wear-resist blade and teeth
- Rock bucket
- Grapple with aligned or crossed teeth
- Fork
- Snow blade

## OTHERS

- Automatic central lubrication
- Weight scale (Electric load weigher)
- Hood protective guard



Like and follow us:



LG-SP-856H-Stage V-WW-A4-27022019-ENG

## Guangxi Liugong Machinery Co., Ltd.

No. 1 Liutai Road, Liuzhou, Guangxi 545007, PR China  
T: +86 772 388 6124 E: overseas@liugong.com  
www.liugong.com

The LiuGong series of logos herein, including but not limited to word marks, device marks, letter of alphabet marks and combination marks, as the registered trademarks of Guangxi Liugong Group Co., Ltd. are used by Guangxi Liugong Machinery Co., Ltd. with legal permission, and shall not be used without permission. Specifications and designs are subject to change without notice. Illustrations and pictures may include optional equipment and may not include all standard equipment. Equipment and options varies by regional availability.